

# TM-U325D/U325PD

## User's Manual

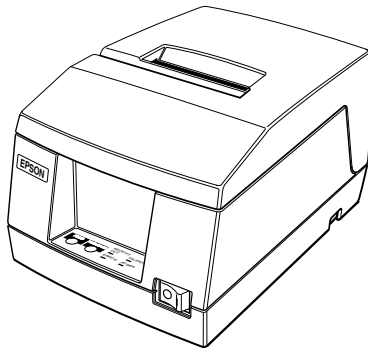

# Printer Parts and Labels

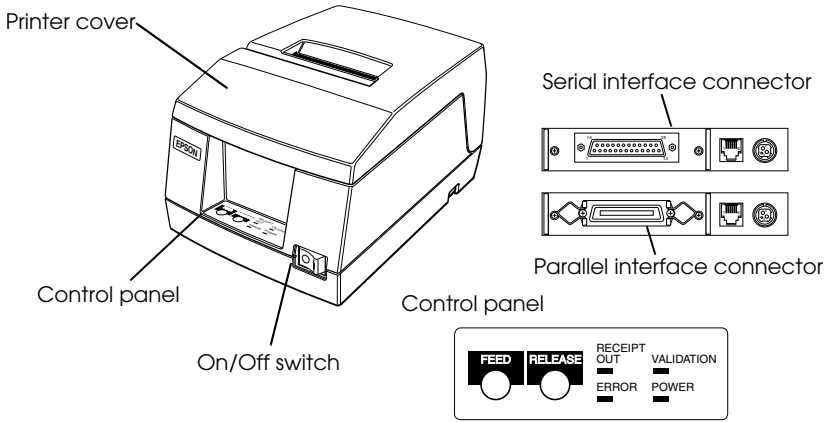

## Labels

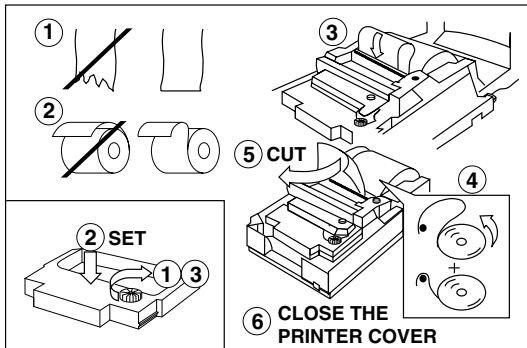

## **CAUTION/ VORSICHT:**

*Print head cover and print head are hot.*

*Druckkopfabdeckung und Druckkopf sind heiß.*



## **CAUTION/ VORSICHT:**

*Caution label for drawer kick-out connector.*

*Vorsichtsetikett für Schnappsteckerbuchse.*

All rights reserved. No part of this publication may be reproduced, stored in a retrieval system, or transmitted in any form or by any means, electronic, mechanical, photocopying, recording, or otherwise, without the prior written permission of Seiko Epson Corporation. No patent liability is assumed with respect to the use of the information contained herein. While every precaution has been taken in the preparation of this book, Seiko Epson Corporation assumes no responsibility for errors or omissions. Neither is any liability assumed for damages resulting from the use of the information contained herein.

Neither Seiko Epson Corporation nor its affiliates shall be liable to the purchaser of this product or third parties for damages, losses, costs, or expenses incurred by purchaser or third parties as a result of: accident, misuse, or abuse of this product or unauthorized modifications, repairs, or alterations to this product, or (excluding the U.S.) failure to strictly comply with Seiko Epson Corporation's operating and maintenance instructions.

Seiko Epson Corporation shall not be liable against any damages or problems arising from the use of any options or any consumable products other than those designated as Original Epson Products or Epson Approved Products by Seiko Epson Corporation.

EPSON and ESC/POS are registered trademarks of Seiko Epson Corporation in Japan and other countries/regions.

**NOTICE:** The contents of this manual are subject to change without notice.

Copyright © 1996, 1999 by Seiko Epson Corporation, Nagano, Japan.

---

## **Standards and Approvals**

The following standards are applied only to the printers that are so labeled. (EMC is tested using the Epson power supplies.)

Europe: CE marking

North America: FCC/ICES-003 Class A

Oceania: AS/NZS CISPR22 Class A

### **WARNING**

This is a Class A product. In a domestic environment this product may cause radio interference in which case the user may be required to take adequate measures.

The connection of a non-shielded printer interface cable to this printer will invalidate the EMC standards of this device.

You are cautioned that changes or modifications not expressly approved by Seiko Epson Corporation could void your authority to operate the equipment.

### **CE marking**

The printer conforms to the following Directives and Norms:

Directive 2004/108/EC

EN 55022 Class A

EN 55024

IEC 61000-4-2

IEC 61000-4-3

IEC 61000-4-4

IEC 61000-4-5

IEC 61000-4-6

IEC 61000-4-11

### **FCC Compliance Statement for American Users**

This equipment has been tested and found to comply with the limits for a Class A digital device, pursuant to Part 15 of the FCC Rules. These limits are designed to provide reasonable protection against harmful interference when the equipment is operated in a commercial environment.

This equipment generates, uses, and can radiate radio frequency energy and, if not installed and used in accordance with the instruction manual, may cause harmful interference to radio communications.

Operation of this equipment in a residential area is likely to cause harmful interference, in which case the user will be required to correct the interference at his own expense.

### **For Canadian Users**

This Class A digital apparatus complies with Canadian ICES-003.

### **À l'intention des utilisateurs canadiens**

Cet appareil numérique de classe A est conforme à la norme canadienne NMB-003.

---

## About This Manual

### Setting Up and Using

- ❑ Chapter 1 contains information on unpacking the printer, setting it up, attaching the paper roll near-end sensor, and setting the DIP switches.
- ❑ Chapter 2 contains information on using the printer.
- ❑ Chapter 3 contains troubleshooting information.

### Reference

- ❑ Chapter 4 contains specifications and character code tables.

### Warnings, Cautions, and Notes

#### **WARNING / WARNUNG:**

*Warnings must be followed carefully to avoid serious bodily injury.*

*Warnhinweise müssen sorgfältig befolgt werden, um Unfälle mit möglicherweise schweren Verletzungen zu vermeiden.*

#### **CAUTION / VORSICHT:**

*Cautions must be observed to avoid minor injury to yourself or damage to your equipment.*

*Vorsichtshinweise müssen sorgfältig befolgt werden, um Unfälle mit der Gefahr leichter Verletzungen oder Schäden am Gerät zu vermeiden.*



#### **Note:**

*Notes have important information and useful tips on the operation of your printer.*

---

## Downloading Drivers, Utilities, and Manuals

Drivers, utilities, and manuals can be downloaded from one of the following URLs.

For customers in North America, go to the following web site:  
<http://www.epsonexpert.com/> and follow the on-screen instructions.

For customers in other countries, go to the following web site:  
<http://www.epson-pos.com/>

---

# **Introduction**

---

## **Features**

The TM-U325D and TM-U325PD are high-quality POS printers that can print a multiple-line validation and on receipt paper (paper roll). The printer has the following features:

- ❑ Easily changeable interface specifications for serial or parallel by exchanging the interface board.
- ❑ Excellent reliability (long life) and good operability (drop-in paper loading).
- ❑ Multiple-line validation printing (possible to print a maximum of 9 lines).
- ❑ Compact and light in weight.
- ❑ High-speed printing through logic-seeking control.
- ❑ Excellent reliability and long life due to adoption of stepping motor, both for moving the carriage and for paper feeding.
- ❑ Flexible line space setting permits printing in accordance with any user-defined format.
- ❑ Conforms with ESC/POS<sup>®</sup>; excellent universality of control.
- ❑ Built-in drawer kick-out interface provides capability to drive two drawers.
- ❑ Selectable character fonts (7 × 9 and 9 × 9).
- ❑ Semi-automatic paper loading capability.
- ❑ AC adapter provides compact power supply.
- ❑ Automatic status back (ASB) function that automatically transmits changes in printer status.

---

## **Accessories**

- ❑ AC adapter
- ❑ EPSON ribbon cassette, ERC-38

---

## **Options**

- ❑ EPSON power supply unit, PS-180
- ❑ Printer fastening tape (Model No. DF-10)

---

## **Restriction of Use**

When this product is used for applications requiring high reliability/safety, such as transportation devices related to aviation, rail, marine, automotive, etc.; disaster prevention devices; various safety devices, etc.; or functional/precision devices, etc.; you should use this product only after giving consideration to including fail-safes and redundancies into your design to maintain safety and total system reliability. Because this product was not intended for use in applications requiring extremely high reliability/safety, such as aerospace equipment, main communication equipment, nuclear power control equipment, or medical equipment related to direct medical care, etc., please make your own judgment on this product's suitability after a full evaluation.

# Chapter 1

---

## Setting Up the Printer

---

### Unpacking

The illustration below shows the items included for the standard specification printer.

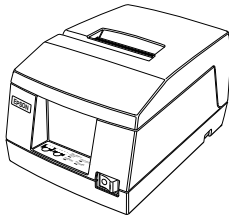

Printer

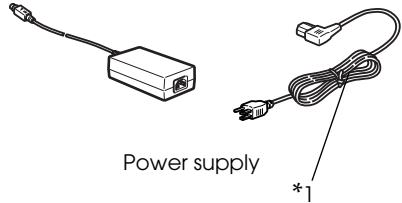

Power supply

\*1

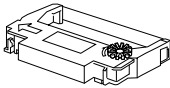

Ribbon cassette

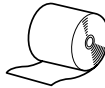

Paper roll

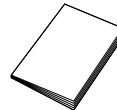

Manual



Spacers for the paper roll  
near-end sensor 2 pcs



Power switch cover

(\*1) The power cord may not be included in the package. If it is not, make sure to use a power cord that complies with the safety standards.

If any item is damaged, please contact your dealer for assistance.

---

### Selecting a Location

Place the printer on a surface that is as horizontal as possible. Make sure that the printer does not tilt more than 15 degrees.

The printer should be installed so that it does not move or vibrate during paper cutting or the drawer kick-out operation.

Fastening tape is available as an option.

---

## Adjusting the Paper Roll Near-End Sensor



### Notes:

Use paper rolls with an inner core diameter of 10.5 to 12.5 mm so that the sensor detects the remaining paper correctly.

When the last portion of a paper roll bears red markings, the marking is sometimes an adhesive that pulls the entire paper roll up. In this case, the sensor may not detect the remaining paper correctly.

If a paper roll easily becomes loose because of the quality of the paper or other factors, incorrect detection of the paper end may result.

1. Make sure that the power supply is disconnected from the printer.
2. Two spacers are included. See the illustration below and decide whether or not you want to use them. Use them if you want the near-end sensor to be triggered when distance A is 3 to 4 mm; otherwise it will be triggered when distance A is approximately 6 mm.

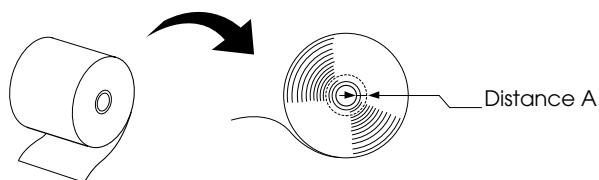

3. Secure the paper roll near-end sensor (and spacers) with two screws. When you insert the spacers, be sure you set the spacers in the direction shown in the illustration.



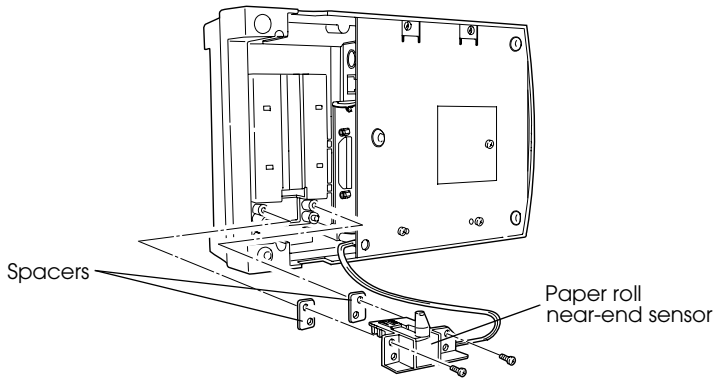

4. Check to be sure that the detecting lever moves freely.

---

## ***Connecting the Cables and Grounding the Printer***

You can connect up to three cables and a grounding wire to the printer. They all connect to the connector panel on the bottom of the printer, which is shown below:

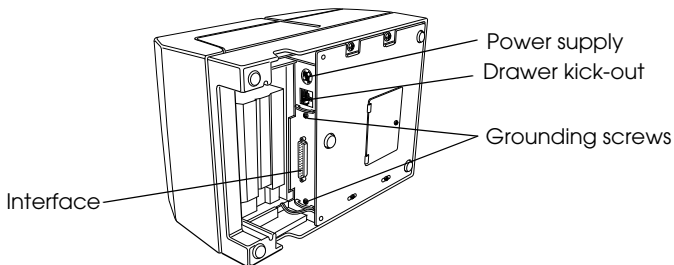

 **Notes:**

*There is a caution label beside the drawer kick-out connector.*

*Depending on the interface installed, the interface connector on your printer may look different from the one illustrated.*

Before connecting any of the cables, make sure that both the printer and the computer are turned off.

## Connecting the Computer

1. Plug the cable into the connector on the printer and tighten the screws on both sides of the cable connector, as shown.

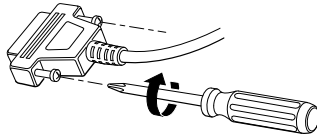

2. Connect the other end of the cable to the connector on your computer.

## Connecting the Drawer



### **WARNING:**

*Use a drawer that matches the printer specification. Using an improper drawer may damage the drawer as well as the printer.*



### **CAUTION:**

*Do not connect a telephone line to the drawer kick-out connector; otherwise the printer and the telephone line may be damaged.*

Plug the drawer cable into the drawer kick-out connector on the bottom of the printer next to the power supply connector.

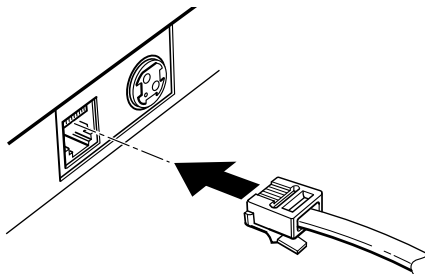

## Anschließen der Lade

### **WARNUNG:**

Eine für den Drucker geeignete Lade verwenden. Bei Verwendung einer falschen Lade kann diese oder der Drucker beschädigt werden.

### **ACHTUNG:**

Kein Telefonkabel an die Schnappsteckerbuchse anschließen, da sonst der Drucker und die Telefonkabel beschädigt werden können.

Das Kabel der Lade an die Schnappsteckerbuchse unten am Drucker neben dem Netzanschluß anschließen.

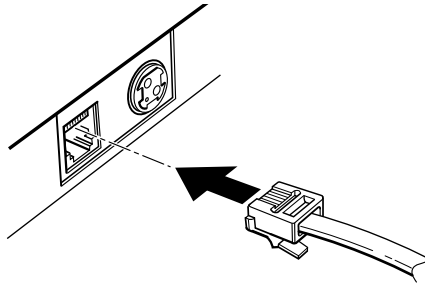

## Grounding the Printer

You need a ground wire to ground your printer. Make sure that the wire meets the specifications below.

Thickness of wire: AWG 18 or equivalent

Diameter of terminal to be attached: 3.2

1. Make sure that the printer is turned off.

2. Connect the ground wire to the printer using the FG screw on the bottom of the printer, as shown.

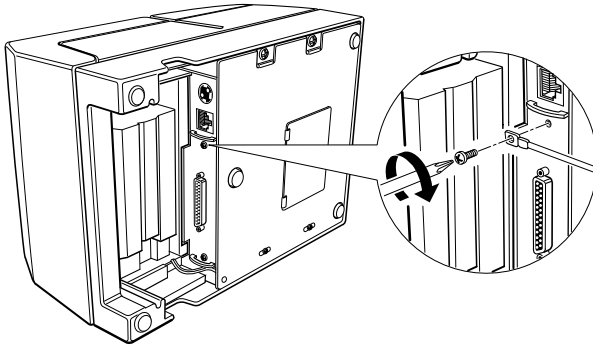

## Connecting the Power Supply

This printer requires an external power supply. Be sure to use a power supply that matches the specifications.



### **WARNING / WARNUNG:**

*Using an incorrect power supply may cause fire or electrical shock.*

*Bei Verwendung der falschen Stromversorgung besteht Brand- oder Stromschlaggefahr.*



### **CAUTION / VORSICHT:**

*When connecting or disconnecting the power supply from the printer, make sure that the power supply is not plugged into an electrical outlet; otherwise you may damage the power supply or the printer.*

*If the power supply's rated voltage and your outlet's voltage do not match, contact your dealer for assistance. Do not plug in the power cord. Otherwise you may damage the power supply or the printer.*

*Beim Anschließen der Stromversorgung an den Drucker und beim Herausziehen der Stromversorgung aus dem Drucker darf die Stromversorgung nicht in eine Steckdose eingesteckt sein. Andernfalls kann die Stromversorgung oder der Drucker beschädigt werden.*

*Wenn die Nennspannung der Stromversorgung und die Spannung der Steckdose nicht übereinstimmen, den Händler um Hilfe bitten. Das Netzkabel nicht einstecken. Andernfalls kann die Stromversorgung oder der Drucker beschädigt werden.*

1. Make sure that the printer's power switch is turned off, and the power supply's power cord is unplugged from the electrical outlet.
2. Plug in the power supply's cord as shown below. Notice that the flat side of the connector faces down.

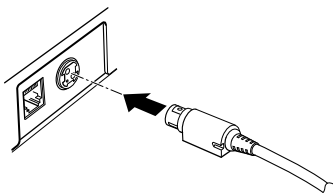

3. Plug the power supply's power cord into an outlet.



**Note:**

*If you ever need to remove the cable, unplug the power supply's power cord from the outlet and then grasp the connector firmly at the arrow mark and pull it straight out.*

---

## **Installing the Ribbon Cassette**

Use the EPSON ERC-38 ribbon cassette for your printer.

Note the label inside the printer cover that can assist you in installing the ribbon.

## **CAUTION / VORSICHT:**

*Never turn the ribbon cassette's feed knob in the opposite direction of the arrow marked on the cassette; otherwise the ribbon cassette may be damaged.*

*Den Transportknopf an der Farbbandkassette nur in die durch den Pfeil gekennzeichnete Richtung drehen. Andernfalls kann die Farbbandkassette beschädigt werden.*

1. Be sure the printer is not receiving data when you replace a ribbon cassette; otherwise data may be lost.
2. Open the printer cover.
3. Turn the ribbon cassette's knob in the direction of the arrow, to take up any slack in the ribbon.

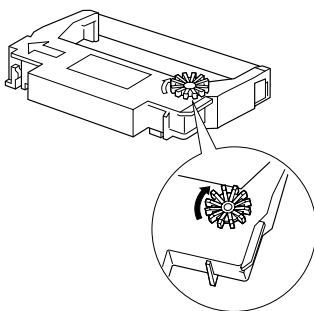

4. Insert the ribbon in the position shown in the illustration below and push the ribbon cassette until it clicks.



### **Note:**

*Make sure that the ribbon is installed between the print head and the platen without wrinkles or creases.*

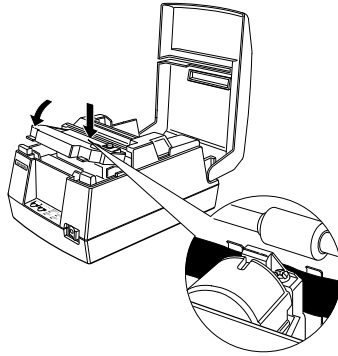

5. Turn the ribbon cassette's knob 5 or 6 times in the direction of the arrow again, to take up any slack in the ribbon.

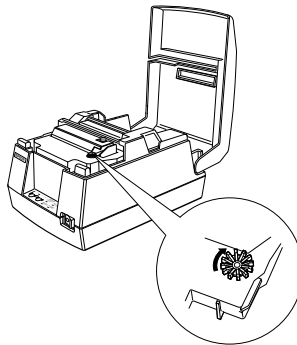

---

## Installing the Paper Roll



### **CAUTION / VORSICHT:**

Take care not to injure your fingers on the manual cutter

- When you remove printed paper
- When you perform other operations such as loading/replacing roll paper

*Darauf achten, dass Sie sich bei den folgenden Arbeiten keine Handverletzungen durch die manuelle Schneidvorrichtung zuziehen:*

- *Beim Herausnehmen des bedruckten Dokuments*
- *Bei der Durchführung von anderen Arbeiten, wie zum Beispiel beim Einlegen/Herausnehmen der Papierrolle.*

 **Notes:**

*Be sure to use a paper roll that meets the specifications.*

*Do not use paper rolls that have the paper glued to the core because the printer cannot detect the paper end correctly. However, if you will stop the printing using the paper roll near-end sensor, you can use glued type paper rolls.*

1. Using scissors, cut the leading edge of the paper roll as shown below.

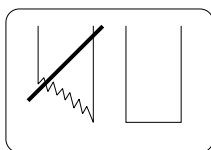

2. Turn on the printer and open the printer cover.
3. Insert the paper roll.

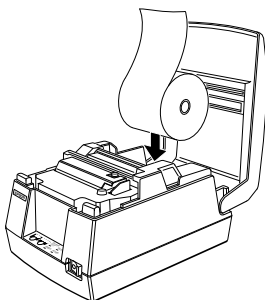

 **Note:**

*Be sure to note the correct direction that the paper comes off the roll as shown below.*

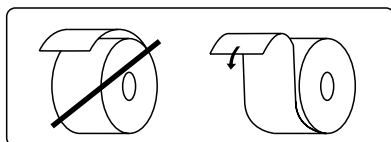



4. Hold both edges of the paper and insert it straight into the paper slot. The printer feeds the paper automatically.

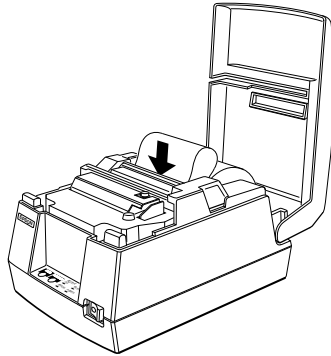

5. Tear off the paper; then close the cover.



**Note:**

*Before closing the cover, make sure that the paper from the paper roll is not slack.*

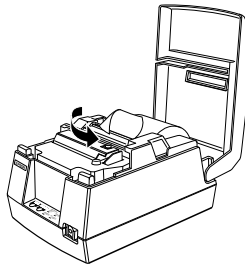

To remove the paper roll, follow the steps below.

1. Open the printer cover.

2. Pull up the paper and cut the paper at the dotted line shown in the illustration below.

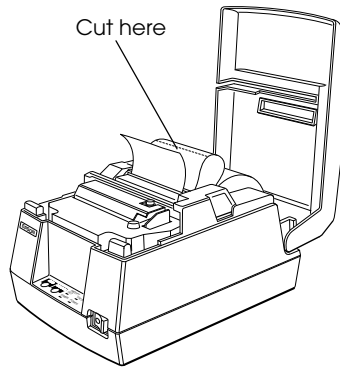

3. Remove the paper roll from the printer.
4. Press the FEED button to remove the remaining paper.

---

## ***Running the Self Test***

Any time that you want to check the performance of your printer, you can run the self test described below. This shows whether your printer is working correctly. It is independent of any other equipment or software.



**Note:**

*Be sure to install the ribbon cassette and the paper roll before you run the self test.*

1. To perform the self test, hold down the FEED button while you turn on the printer with the power switch.
2. The printer prints the current printer settings and then the RECEIPT OUT light flashes to indicate that the printer is in the test printing standby state.
3. Press the FEED button to start the second part of the test, in which the printer prints a pattern using the built-in character set.

4. After the printer completes a certain number of lines, it prints the following:

\*\*\* completed \*\*\*

Then it enters the normal mode.



**Note:**

*If you want to pause the self test manually, press the FEED button. Press the FEED button again to continue the self test.*

---

## **Setting the DIP Switches**

### **Einstellen der DIP-Schalter**



#### **CAUTION / VORSICHT:**

*Turn off the printer while removing the DIP switch cover to prevent an electrical short, which can damage the printer.*

*Den Drucker vor Abnahme der DIP-Schalterabdeckung ausschalten, um einen Kurzschluß zu verhindern, durch den der Drucker beschädigt werden könnte.*

If you have special requirements, you can change the DIP switch settings.

Wenn besondere Anforderungen vorliegen, können die DIP-Schaltereinstellungen geändert werden.

1. Make sure that the printer is off.  
Sicherstellen, daß der Drucker ausgeschaltet ist.
2. Turn the printer over and remove the DIP switch access cover, as shown below.  
Den Drucker umdrehen und die DIP-Schalterabdeckung abnehmen (siehe Abbildung).

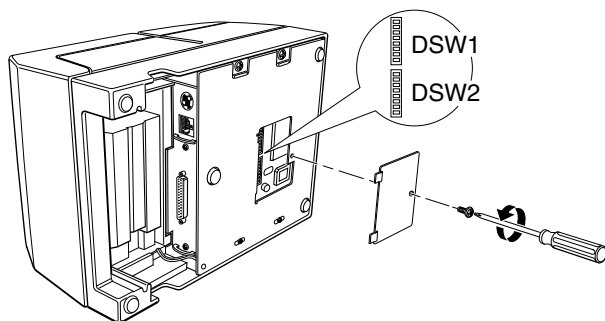

3. There are two sets of switches. Notice that ON is marked on each set of switches. Use tweezers or another narrow tool to move the switches.

Es gibt zwei Gruppen von Schaltern. Auf beiden Gruppen ist die Einstellung ON (EIN) markiert. Zum Verschieben der Schalter eine Pinzette oder ein anderes kleines Werkzeug verwenden.

4. Use the following tables to set the DIP switches. Numbers starting with 1 are in the first set, and numbers starting with 2 are in the second.

Die DIP-Schalter anhand der folgenden Tabellen einstellen. Schalter, die mit 1 beginnen, befinden sich in der ersten Gruppe, Schalter, die mit 2 beginnen, in der zweiten Gruppe.

## Serial Interface (TM-U325D)

These are the settings for printers equipped with a serial interface.

*DIP Switch Set 1*

| Switch | Function                | ON       | OFF       |
|--------|-------------------------|----------|-----------|
| 1-1    | Data reception error    | Ignored  | Prints“?” |
| 1-2    | Receive buffer capacity | 45 bytes | 4K bytes  |
| 1-3    | Handshaking             | XON/XOFF | DTR/DSR   |
| 1-4    | Word length             | 7 bits   | 8 bits    |
| 1-5    | Parity check            | Yes      | No        |

### DIP Switch Set 1

| Switch   | Function                             | ON   | OFF |
|----------|--------------------------------------|------|-----|
| 1-6      | Parity selection                     | Even | Odd |
| 1-7, 1-8 | Transmission speed (see table below) |      |     |

### Transmission Speed

| Transmission Speed (BPS)-bits per second | 1-7 | 1-8 |
|--|-----|-----|
| 2400                                     | ON  | ON  |
| 4800                                     | OFF | ON  |
| 9600                                     | ON  | OFF |
| 19200                                    | OFF | OFF |

### DIP Switch Set 2

| Switch   | Function   | ON                  | OFF                             |
|----------|--|---------------------|---------------------------------|
| 2-1      | Handshaking (BUSY condition)                                     | Receive buffer full | Off line or receive buffer full |
| 2-2      | Not defined  | —                   | —                               |
| 2-3      | Select number of characters per line (CPL) 7 × 9 font/9 × 9 font | 42CPL/35CPL         | 40CPL/33CPL                     |
| 2-4, 2-5 | Not defined  | —                   | —                               |
| 2-6      | Internal use   | —                   | Fixed to Off                    |
| 2-7      | I/F pin 6 reset signal   | Enabled             | Disabled                        |
| 2-8      | I/F pin 25 reset signal  | Enabled             | Disabled                        |



#### Notes:

*Changes in DIP switch settings (excluding switches 2-7 and 2-8) are recognized only when the printer power is turned on or when the printer is reset by using the interface. If the DIP switch setting is changed after the printer power is turned on, the change does not take effect until the printer is turned on again or is reset.*

*If DIP switch 2-7 or 2-8 is turned on while the printer is turned on, the printer may be reset, depending on the signal state.*

*DIP switches should not be changed while the printer power is on.*

## Parallel Interface (TM-U325PD)

These are the settings for printers equipped with a parallel interface.

### DIP Switch Set 1

| Switch  | Function                | ON       | OFF      |
|---------|-------------------------|----------|----------|
| 1-1     | Auto line feed          | Enabled  | Disabled |
| 1-2     | Receive buffer capacity | 45 bytes | 4K bytes |
| 1-3~1-8 | Not defined             | —        | —        |

### DIP Switch Set 2

| Switch   | Function  | ON                  | OFF                             |
|----------|---|---------------------|---------------------------------|
| 2-1      | Handshaking (BUSY condition)  | Receive buffer full | Off line or receive buffer full |
| 2-2      | Not defined   | —                   | —                               |
| 2-3      | Select number of characters per line (CPL)<br>7 × 9 font/9 × 9 font | 42CPL/35CPL         | 40CPL/33CPL                     |
| 2-4, 2-5 | Not defined   | —                   | —                               |
| 2-6      | Internal use  | —                   | Fixed to Off                    |
| 2-7      | Not defined   | —                   | —                               |
| 2-8      | I/F pin 31 reset signal   | Fixed to On         | —                               |



#### Notes:

*Changes in DIP switch settings are recognized only when the printer power is turned on or when the printer is reset by using the interface. If the DIP switch setting is changed after the printer power is turned on, the change does not take effect until the printer is turned on again or is reset.*

5. Replace the DIP switch cover and secure it with the screw.  
Die DIP-Schalterabdeckung wieder aufsetzen und mit der Schraube befestigen.

---

## Using the Power Switch Cover Verwendung der Netzschalterabdeckung



### **WARNING / WARNUNG:**

*If an accident occurs when the power switch cover is attached, unplug the power supply cord from the outlet immediately; otherwise the printer may be damaged.*

*Wenn ein Unfall auftritt und die Netzschalterabdeckung aufgesetzt ist, das Netzkabel sofort aus der Steckdose herausziehen. Andernfalls kann der Drucker beschädigt werden.*

You can use the provided power switch cover to protect the power switch from accidental or improper operation. Attach the cover as shown in the illustration below.

You can turn the power on or off with the switch cover attached by inserting a pointed object (like a ball point pen) through either of the two small holes on the switch cover.

Mit der mitgelieferten Netzschalterabdeckung läßt sich der Netzschalter vor versehentlicher oder unbefugter Benutzung schützen. Die Abdeckung ist wie in der Abbildung dargestellt anzubringen.

Um den Drucker ein- und auszuschalten, während die Netzschalterabdeckung aufgesetzt ist, einen spitzen Gegenstand (wie z.B. einen Kugelschreiber) in eine der beiden kleinen Öffnungen in der Abdeckung einführen.

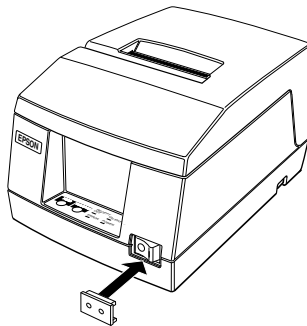

---

## ***Affixing the Fastening Tape (Option)***

Two sets of tape are included as an option to fasten your printer to a countertop or other surface. Follow the steps below:

1. Clean the countertop or other surface where the printer will be installed.
2. Peel the green backing paper off of one side of each of the two sets of tapes and affix them to the bottom of the printer, as shown below.

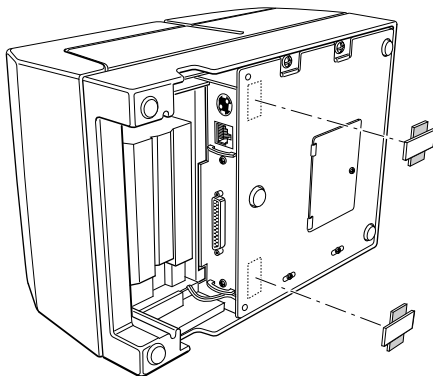

3. Peel the green backing paper off of the other side of the tapes.
4. Press the printer onto the countertop; it will be held firmly in place by the fastening tape.



## Chapter 2

# Using the Printer

---

## Operating the Control Panel

---

You can feed or release paper with the buttons on the control panel. The indicator lights help you monitor the printer's status.

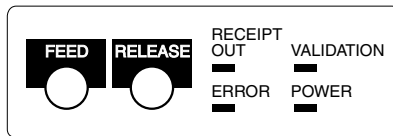

### Switch

The power switch on the front of the printer turns the printer on and off.

### Buttons

#### FEED

Press the FEED button once to advance the paper roll one line. You can also hold down the FEED button to feed the paper continuously.

#### RELEASE

Press the RELEASE button to release the validation paper.



#### Notes:

*These buttons can be disabled by the ESC c 5 command, but they work whenever the printer cover is open, even if they have been disabled by the ESC c 5 command.*

*The power switch and FEED button can also be used to start the self test.*

## Indicator lights

The control panel lights provide information on printer conditions.

### POWER (Green)

The POWER light is on when the printer power is on.

### RECEIPT OUT (Red)

This light is on when the paper roll is at the end or near the end.

This light flashes in the following cases. When it flashes, press the FEED button.

- ❑ In the self-test standby state

### VALIDATION (Green)

The light is on when validation paper is inserted and the printer is ready to print. The light flashes when the printer is in the validation insertion/removal waiting state.

### ERROR (Red)

This light is on when the printer is off line (except during paper feed using the FEED button and during the self-test). It flashes to indicate an error condition.

The flashing pattern shown below indicates that the temperature of the print head is too high. The printer recovers automatically and resumes printing when the head cools.



If the printer stops working and the ERROR light is flashing, turn the printer off, check for jammed paper, and remove the paper by following the instructions on page 3-3, if necessary. Then turn the printer back on. If the printer still does not work, unplug the power supply cord from the outlet immediately, and contact a qualified service person.



### **CAUTION / VORSICHT:**

*Take care not to injure your fingers on the manual cutter*

- *When you remove printed paper*
- *When you perform other operations such as loading/replacing roll paper*

*Darauf achten, dass Sie sich bei den folgenden Arbeiten keine Handverletzungen durch die manuelle Schneidvorrichtung zuziehen:*

- *Beim Herausnehmen des bedruckten Dokuments*
- *Bei der Durchführung von anderen Arbeiten, wie zum Beispiel beim Einlegen/Herausnehmen der Papierrolle.*

*The print head becomes very hot during printing. Allow it to cool before you reach into the printer.*

*Der Druckkopf wird beim Drucken sehr heiß. Warten, bis er sich abgekühlt hat, bevor Sie in den Drucker fassen.*

*Do not use aerosol sprayers containing flammable gas inside or around this product. Doing so may cause fire.*

*Verwenden Sie keine brennbaren Sprühmittel in und in der Nähe des Gerätes. Brandgefahr!*

---

## Validation Paper Handling



### Notes:

Use only validation paper that matches the printer's specifications. See *Paper Specifications* in Chapter 4.

Be sure that a paper roll is loaded before you use validation paper.

Be sure that the validation paper is flat, without curls, folds, or wrinkles.

1. Send appropriate control commands from the computer to print on validation paper.
2. When the VALIDATION light flashes, insert the validation paper into the validation paper inlet using the right edge of the validation paper inlet as a guide. (Follow steps ① and ② in the illustration.)

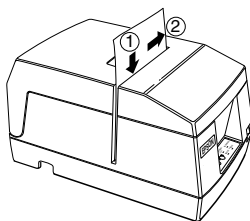

3. Make sure you insert the validation paper into the inlet as far as it will go.
4. When the validation paper is detected by the sensor, the VALIDATION light is changed from flashing to on and the paper is automatically drawn into the printer and printing begins.
5. When the VALIDATION light begins flashing after printing, remove the validation.

## Chapter 3

---

# Troubleshooting

---

---

## Troubleshooting

This chapter gives solutions to some of the more common printer problems.

### General Problems

---

#### The lights on the control panel do not come on.

---

Make sure that the power supply cords are correctly plugged into the printer, the power unit, and to the power outlet.

Make sure that power is supplied to the power outlet. If the outlet is controlled by a switch or timer, use another outlet.

### Printing Problems

---

#### The **ERROR** light is flashing and the printer does not print.

---

First, turn off the printer and check for a paper jam. (See the paper jam description on page 3-3.)

If there is no paper jam and the printer has been printing for quite a while, the print head may be overheated. If the print head is overheated, the printer will resume printing when the head has cooled (usually about 30 seconds).

If there is no paper jam and the print head is not overheated, turn off the printer and turn it back on after about 10 seconds. If the printer still does not work, unplug the power supply cord from the outlet immediately. Then contact a qualified service person.

---

**The ERROR light is off, but nothing is printed.**

---

Try to run the self test to check that the printer works properly. See the self test instructions in Chapter 1 to run the self test. If the self test does not work, contact your dealer or a qualified service person.

If the self test works properly, check the following:

1. Check the connection at both ends of the interface cable between the printer and the computer. Also make sure that this cable meets the specifications for both the printer and the computer.
2. The data transmission settings may be different between the printer and computer. Make sure that the printer's DIP switch settings for data transmission are the same as the computer's. You can print the printer's interface settings using the self test.

If the printer still does not print, contact your dealer or a qualified service person.

---

**The printer sounds like it is printing, but nothing is printed.**

---

The ribbon cassette may not be installed properly. See the instructions in Chapter 1.

The ribbon may be worn out. Replace the ribbon cassette as described in Chapter 1.

---

**The printout is faint.**

---

The ribbon may be worn out. Replace the ribbon cassette as described in Chapter 1.

---

## A line of dots is missing in the printout.

---

The print head may be damaged. Stop printing and contact your dealer or a qualified service person.

### **Removing Jammed Paper**

Follow these steps to clear a paper jam:



### **CAUTION / VORSICHT:**

*The print head becomes very hot during printing. Allow it to cool before you reach into the printer.*

*Der Druckkopf wird beim Drucken sehr heiß. Warten, bis er sich abgekühlt hat, bevor Sie in den Drucker fassen.*

1. Open the printer cover.
2. Pull up the paper and cut the paper at the dotted line shown in the illustration below.

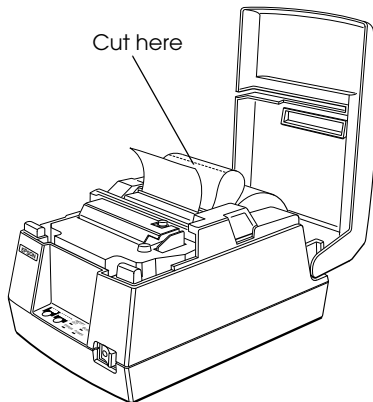

3. Remove the paper roll from the printer.
4. Remove the ribbon cassette.

5. Loosen the screw on the print head cover as shown below.

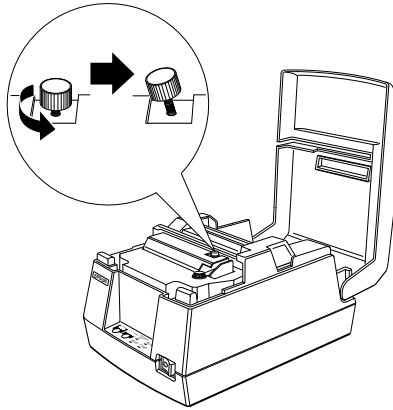

6. Lift up the print head cover.

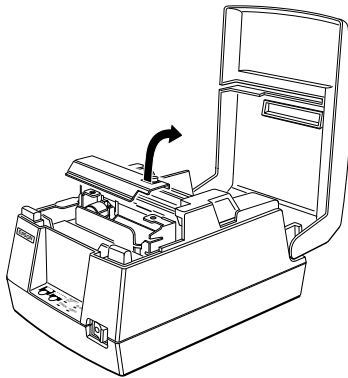

7. Remove all the jammed paper.



**Note:**

*Do not pull the jammed paper in the opposite direction of paper feeding.*

8. Replace the print head cover and secure it with the screw.
9. Replace the ribbon cassette and paper roll; then close the printer cover.



---

## Hexadecimal Dump

This feature allows experienced users to see exactly what data is coming to the printer. This can be useful in finding software problems. When you turn on the hex dump function, the printer prints all commands and other data in hexadecimal format along with a guide section to help you find specific commands.

To use the hexadecimal dump feature, follow these steps:

1. Turn on the printer while you hold down the FEED button; then close the cover.
2. When the printer enters the hexadecimal dump mode, it prints "Hexadecimal Dump."
3. Run any software program that sends data to the printer. The printer prints all the codes it receives in a two-column format. The first column contains the hexadecimal codes and the second column gives the ASCII characters that correspond to the codes.

```
Hexadecimal Dump
1B 40 1B 21 30 41 42 43 . @ . ! 0 A B C
44 45 46 47 0A           DE F G.
```

- A period (.) is printed for each code that has no ASCII equivalent.
  - During the hexadecimal dump, all commands except **DLE EOT** and **DLE ENQ** are disabled.
4. When the printing finishes, turn off the printer or reset it to turn off the hexadecimal dump mode.



**Note:**

*Insufficient print data to fill the last line can be printed by setting the printer off-line.*



**Printing Specifications**

|                                    |  |
|------------------------------------|--|
| <b>Printing Method:</b>            | Serial impact dot-matrix   |
| <b>Head wire configuration:</b>    | 9-pin serial configuration   |
| <b>Printing Direction:</b>         | Bi-directional, logic-seeking  |
| <b>Characters/line (default):</b>  | See table on page 4-2.   |
| <b>Character spacing (default)</b> | See table on page 4-2.   |
| <b>Fonts A and B:</b>              |  |
| <b>Printing speed:</b>             | Approx. 3.5 lines/second (40 columns, 16 cpi)<br>Approx. 6.4 lines/second (16 columns, 16 cpi)<br>(excluding data transmission time and processing time) |

(cpi: characters per 25.4 mm (characters per inch))

**Note:**

When printing exceeds the allowable print duty cycle, the printer automatically stops printing. In this case, the printing speed described above is not guaranteed.

---

## Character Specifications

**Number of characters**                      Alphanumeric characters: 95  
 Extended graphics: 128 × 8 pages,  
 International characters: 32

**Character structure:**            7 × 9 (the total number of dots for each horizontal line: 400 in half dot units)  
 9 × 9 (the total number of dots for each horizontal line: 400 in half dot units)

**Character size:**                    See table below.

### *Character Sizes, Character Spacing, Character Columns*

| Character structure |           | Character size<br>W x H (mm) | Character spacing<br>Dot space | CPL | CPI  |
|---------------------|-----------|------------------------------|--------------------------------|-----|------|
| W x H (mm)          | Character |                              |                                |     |      |
| 7 x 9               | ANK       | 1.2 x 3.1                    | 3 half dots                    | 40  | 16   |
|                     | Graphics  | 1.7 x 3.1                    | 0                              | 40  | 16   |
| 9 x 9               | ANK       | 1.6 x 3.1                    | 3 half dots                    | 33  | 13.3 |
|                     | Graphics  | 2.0 x 3.1                    | 0                              | 33  | 13.3 |
| 7 x 9               | ANK       | 1.2 x 3.1                    | 2 half dots                    | 42  | 17.8 |
|                     | Graphics  | 1.6 x 3.1                    | 0                              | 42  | 17.8 |
| 9 x 9               | ANK       | 1.6 x 3.1                    | 2 half dots                    | 35  | 14.5 |
|                     | Graphics  | 1.9 x 3.1                    | 0                              | 35  | 14.5 |

(cpl: characters per line)

(cpi: characters per 25.4 mm (characters per inch))

**Notes:**

- The default is 7 x 9.
- 2-dot spacing in half dot units and 3-dot spacing in half dot units depend on the DIP switch setting.

---

## ***Paper Specifications***

|                           |   |
|---------------------------|---|
| <b>Paper feed method:</b> | Friction feed   |
| <b>Paper feed pitch:</b>  | Default 4.23 mm {1/6 inch}<br><br>Can be set in units of 0.176 mm {1/144 inch} by commands. |
| <b>Paper feed speed:</b>  | Approx. 105.918 mm {4.17 inches}/second (25 lines/second) (continuous feeding)              |

### **Paper size and weight:**

#### **Paper roll:**

#### **Normal paper (single-ply)**

|                             |   |
|-----------------------------|---|
| <b>Size:</b>                | Width 76 mm $\pm$ 0.5 mm {3.0" $\pm$ 0.02"}   |
| <b>Maximum outside dia:</b> | 83 mm {3.27"}   |
| <b>Thickness:</b>           | 0.06 to 0.085 mm {.0024 to .0033"}  |
| <b>Mass:</b>                | 52.3 to 64.0 g/m <sup>2</sup> {13.9 to 17 lbs} (45 to 55 Kg {20.41 to 24.94 lbs}/1000 sheets/1091 mm $\times$ 788 mm {43.00" $\times$ 31.02"} |

## Pressure sensitive paper

Maximum 1 original + 2 copies

Size: Width 76 mm  $\pm$  0.5 mm  
{3.0"  $\pm$  0.02"}

Maximum 83 mm {3.27"}  
outside dia:

Thickness: 0.05 to 0.08 mm {.0020 to  
.0031"}  
(Total thickness should  
be 0.2 mm or less and  
each sheet should be 0.05  
to 0.08 mm.)

Recommend MITSUBISHI PAPER  
-ed paper: MILLS, LTD.

Non-carbon paper  
(blue color)

Top and middle sheets:  
N40Hi  
(thickness: 0.06 mm,  
mass: 47.2 g/m<sup>2</sup>)

Bottom sheet: N60  
(thickness: 0.08 mm,  
mass: 68.0 g/m<sup>2</sup>)

### Note:

When using original + 2 copies ( the total is 3), the edges of the paper might fold when the temperature is 34°C and the humidity is 90%.

|   |  |
|---|--|
| <b>Validation paper:</b>                                | Normal, pressure sensitive, and carbon copy paper  |
| <b>Paper size (W × L):</b>                              | 135 mm × 70 mm (minimum) to 182 mm × 182 mm (maximum)<br>{5.31" × 2.76" to 7.17" × 7.17"}<br>(maximum 9 lines at 4.23 mm {.17"} pitch)   |
| <b>Single-ply paper thickness (without copy paper):</b> | 0.09 mm to 0.12 mm {.0035" to .0047"}  |
| <b>Copy paper thickness:</b>                            | Backing paper: 0.07 mm to 0.12 mm {.0028" to .0047"}<br><br>Copy and original paper: 0.04 mm to 0.07 mm {.0016" to .0028"}<br><br>Carbon copy paper: Approximately 0.035 mm {.00138"}  |
|   | Total thickness: 0.09 mm to 0.31 mm {.0035" to .012"}  |
| <b>Example:</b>   | Original + 2-ply copy<br>Original paper: 0.04 mm {.0016"}<br>Carbon copy paper: 0.07 mm {.0028"}<br>(0.035 mm {.0138"} × 2 sheets)<br>Copy paper: 0.04 mm {.0016"}<br>Backing paper: 0.07 mm {.0028"}<br>Roll paper: 0.08 mm {.0031"}<br>Total thickness: 0.30 mm {.0118"} |

## Copy capability

### **Paper roll and validation paper:**

Copy capability is greatly influenced by the ambient temperature, so printing must be performed under the conditions described in the table below.

*Relationship between ambient temperature and number of copies*

*Paper roll and validation paper:*

| <b>Number of copies</b> | <b>Ambient temperature</b> |
|-------------------------|----------------------------|
| Original + 2 copies     | 10° to 40°C {50° to 104°F} |
| Original + 1 copy       | 5° to 50°C {41° to 122°F}  |

### **Notes on validation paper**

- ❑ For correct validation printing, be sure that a paper roll is loaded before you use validation paper. Also be aware that the printing on validation paper may also be visible on the roll paper if the roll paper is pressure-sensitive paper.
- ❑ Use validation paper that is flat, without curls, folds, warps, or wrinkles, especially at the paper edge. Otherwise, the paper may become ink stained or the ribbon may get caught in the printer mechanism.
- ❑ Choose validation paper carefully when glue is on the edge, since paper feeding and insertion are affected by gluing conditions (e.g., glue quality, method, and length) and glue location.
- ❑ Using a multi-ply copy paper with a thick middle sheet may decrease copying capability.
- ❑ Printing noise may change depending on paper thickness. Noise may increase when thick single-ply paper is used.



- ❑ Validation paper with holes (e.g., sprocket holes) within the areas shown below must not be used. Otherwise, the paper cannot be detected by the paper sensor. Translucent paper must not be used.

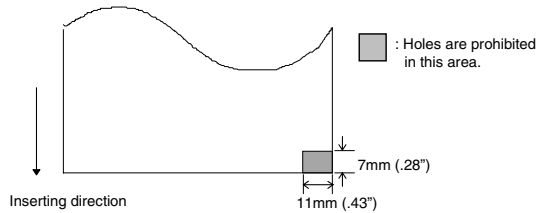

---

## ***Power Supply***

Be sure to use a safety-standards-applied power source that meets the following specifications.

Rated output: 24 V/2.0 A or more, Maximum output: 240 VA or less

---

## **Reliability**

**Life:** 20,000,000 lines

- ❑ End of Life is defined as the point at which the printer reaches the beginning of the Wearout Period.

**MTBF:** 180,000 hours

- ❑ Failure is defined as Random Failure occurring at the time of the Random Failure Period.

**MCBF:** 49,000,000 lines

- ❑ This is an average failure interval based on failures relating to wearout and random failures up to the life of 20 million lines.

**Print head life:** 150 million characters (when printing an average of 2 dots/wire per character)

**Validation switching operation life:** 500,000 transactions

---

# Environmental Conditions

## Temperature

|           |  |
|-----------|--|
| Operating | 0 to 50 °C (32 to 122 °F)<br>(when the temperature is 30 °C or more, there is a limitation for the humidity. Refer to the figure below.) |
| Storage   | -10 to 50 °C (14 to 122 °F)<br>(except for paper, and a ribbon)  |

## Humidity

|           |   |
|-----------|---|
| Operating | 10 to 90% RH                                    |
| Storage   | 10 to 90% RH<br>(except for paper and a ribbon) |

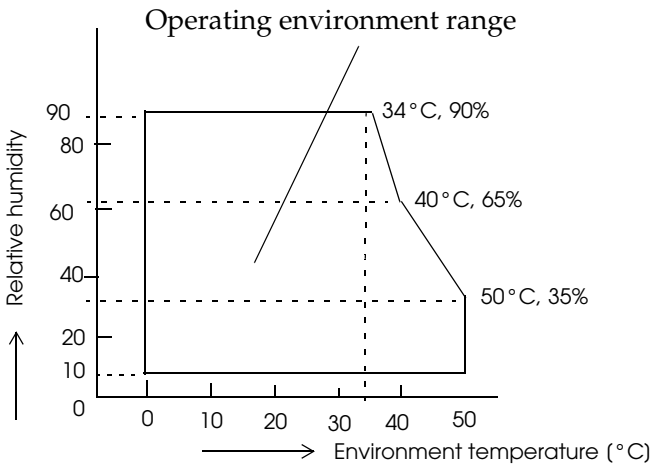

# Character Code Tables

SP in a table represents space.

Page 0 (PC437: U.S.A., Standard Europe) (International character set: U.S.A)

| HEX | 0    | 1    | 2    | 3    | 4    | 5    | 6    | 7    | 8    | 9    | A    | B    | C    | D    | E    | F    |      |
|-----|------|------|------|------|------|------|------|------|------|------|------|------|------|------|------|------|------|
| HEX | BIN  | 0000 | 0001 | 0010 | 0011 | 0100 | 0101 | 0110 | 0111 | 1000 | 1001 | 1010 | 1011 | 1100 | 1101 | 1110 | 1111 |
| 0   | 0000 | NUL  | DLE  | SP   | 0    | @    | P    |      | Ç    | È    | á    | â    | Û    | Ü    | Ý    | à    | ≡    |
| 1   | 0001 |      | XON  | !    | 1    | A    | Q    | a    | q    | ú    | æ    | í    | ï    | ±    | ²    | ³    | ±    |
| 2   | 0010 |      | "    | "    | 2    | B    | R    | b    | r    | é    | œ    | ó    | ö    | τ    | τ    | Γ    | ≥    |
| 3   | 0011 |      | XOFF | #    | 3    | C    | S    | c    | s    | â    | ô    | ù    | í    | †    | †    | π    | ≤    |
| 4   | 0100 | EOT  |      | \$   | 4    | D    | T    | d    | t    | ä    | ö    | ñ    | †    | –    | –    | Σ    | ƒ    |
| 5   | 0101 | ENQ  |      | %    | 5    | E    | U    | e    | u    | ä    | ö    | ñ    | †    | –    | –    | σ    | ƒ    |
| 6   | 0110 |      | &    | &    | 6    | F    | V    | f    | v    | ä    | ü    | ä    | †    | †    | †    | μ    | ÷    |
| 7   | 0111 |      | '    | '    | 7    | G    | W    | g    | w    | ç    | ü    | ö    | †    | †    | †    | τ    | ≈    |
| 8   | 1000 |      | (    | (    | 8    | H    | X    | h    | x    | é    | ÿ    | ç    | †    | †    | †    | φ    | ²    |
| 9   | 1001 | HT   | )    | )    | 9    | I    | Y    | i    | y    | è    | ö    | †    | †    | †    | †    | θ    | •    |
| A   | 1010 | LF   | *    | *    | :    | J    | Z    | j    | z    | è    | ü    | †    | †    | †    | †    | Ω    | •    |
| B   | 1011 |      | ESC  | +    | ;    | K    | [    | k    | {    | ì    | φ    | †    | †    | †    | †    | δ    | √    |
| C   | 1100 | FF   | FS   | <    | <    | L    | \    | l    |      | í    | æ    | †    | †    | †    | †    | ∞    | ñ    |
| D   | 1101 | CR   | GS   | =    | =    | M    | ]    | m    | }    | î    | ÿ    | †    | †    | †    | †    | ∞    | ²    |
| E   | 1110 |      | .    | >    | >    | N    | ^    | n    | ~    | À    | Pt   | «    | †    | †    | †    | €    | ■    |
| F   | 1111 |      | /    | ?    | ?    | O    | _    | o    | SP   | Á    | †    | »    | †    | †    | †    | ∩    | SP   |
|     |      | 15   | 31   | 47   | 63   | 79   | 95   | 111  | 127  | 143  | 159  | 175  | 191  | 207  | 223  | 239  | 255  |

Page 1 (Katakana)

|     | HEX  | 8     | 9     | A    | B     | C     | D     | E     | F     |
|-----|------|-------|-------|------|-------|-------|-------|-------|-------|
| HEX | BIN  | 1000  | 1001  | 1010 | 1011  | 1100  | 1101  | 1110  | 1111  |
| 0   | 0000 | ┌ 128 | ┌ 144 | SP   | ┌ 176 | ┌ 192 | ┌ 208 | ┌ 224 | ┌ 240 |
| 1   | 0001 | └ 129 | └ 145 | 。    | └ 177 | └ 193 | └ 209 | └ 225 | └ 241 |
| 2   | 0010 | ┌ 130 | ┌ 146 | イ    | ┌ 178 | ┌ 194 | ┌ 210 | ┌ 226 | ┌ 242 |
| 3   | 0011 | ┌ 131 | ┌ 147 | ウ    | ┌ 179 | ┌ 195 | ┌ 211 | ┌ 227 | ┌ 243 |
| 4   | 0100 | ┌ 132 | ┌ 148 | エ    | ┌ 180 | ┌ 196 | ┌ 212 | ┌ 228 | ┌ 244 |
| 5   | 0101 | ┌ 133 | ┌ 149 | オ    | ┌ 181 | ┌ 197 | ┌ 213 | ┌ 229 | ┌ 245 |
| 6   | 0110 | ┌ 134 | ┌ 150 | カ    | ┌ 182 | ┌ 198 | ┌ 214 | ┌ 230 | ┌ 246 |
| 7   | 0111 | ┌ 135 | ┌ 151 | キ    | ┌ 183 | ┌ 199 | ┌ 215 | ┌ 231 | ┌ 247 |
| 8   | 1000 | ┌ 136 | ┌ 152 | ク    | ┌ 184 | ┌ 200 | ┌ 216 | ┌ 232 | ┌ 248 |
| 9   | 1001 | ┌ 137 | ┌ 153 | ケ    | ┌ 185 | ┌ 201 | ┌ 217 | ┌ 233 | ┌ 249 |
| A   | 1010 | ┌ 138 | ┌ 154 | コ    | ┌ 186 | ┌ 202 | ┌ 218 | ┌ 234 | ┌ 250 |
| B   | 1011 | ┌ 139 | ┌ 155 | サ    | ┌ 187 | ┌ 203 | ┌ 219 | ┌ 235 | ┌ 251 |
| C   | 1100 | ┌ 140 | ┌ 156 | シ    | ┌ 188 | ┌ 204 | ┌ 220 | ┌ 236 | ┌ 252 |
| D   | 1101 | ┌ 141 | ┌ 157 | ス    | ┌ 189 | ┌ 205 | ┌ 221 | ┌ 237 | ┌ 253 |
| E   | 1110 | ┌ 142 | ┌ 158 | セ    | ┌ 190 | ┌ 206 | ┌ 222 | ┌ 238 | ┌ 254 |
| F   | 1111 | ┌ 143 | ┌ 159 | ソ    | ┌ 191 | ┌ 207 | ┌ 223 | ┌ 239 | ┌ 255 |

Page 2 (PC850: Multilingual)

|     | HEX  | 8        | 9        | A                    | B        | C        | D        | E        | F                    |
|-----|------|----------|----------|----------------------|----------|----------|----------|----------|----------------------|
| HEX | BIN  | 1000     | 1001     | 1010                 | 1011     | 1100     | 1101     | 1110     | 1111                 |
| 0   | 0000 | Ç<br>128 | É<br>144 | á<br>160             | ☐<br>176 | Ł<br>192 | Ǿ<br>208 | Ó<br>224 | —<br>240             |
| 1   | 0001 | ü<br>129 | æ<br>145 | í<br>161             | ☐<br>177 | ł<br>193 | Đ<br>209 | β<br>225 | ±<br>241             |
| 2   | 0010 | é<br>130 | Æ<br>146 | ó<br>162             | ☐<br>178 | Ṭ<br>194 | Ê<br>210 | Ô<br>226 | =<br>242             |
| 3   | 0011 | â<br>131 | ô<br>147 | ú<br>163             | <br>179  | ƒ<br>195 | Ë<br>211 | Ò<br>227 | $\frac{3}{4}$<br>243 |
| 4   | 0100 | ä<br>132 | ö<br>148 | ñ<br>164             | †<br>180 | —<br>196 | È<br>212 | ō<br>228 | 244                  |
| 5   | 0101 | à<br>133 | ò<br>149 | Ñ<br>165             | Ā<br>181 | †<br>197 | ı<br>213 | Ö<br>229 | §<br>245             |
| 6   | 0110 | â<br>134 | û<br>150 | ä<br>166             | Ā<br>182 | ã<br>198 | í<br>214 | μ<br>230 | ÷<br>246             |
| 7   | 0111 | ç<br>135 | ù<br>151 | ó<br>167             | Ā<br>183 | Ā<br>199 | î<br>215 | þ<br>231 | ˆ<br>247             |
| 8   | 1000 | ê<br>136 | ÿ<br>152 | ć<br>168             | ©<br>184 | Ł<br>200 | ÿ<br>216 | þ<br>232 | °<br>248             |
| 9   | 1001 | ë<br>137 | ö<br>153 | ®<br>169             | ¶<br>185 | ƒ<br>201 | ı<br>217 | Ú<br>233 | ˆ<br>249             |
| A   | 1010 | è<br>138 | Û<br>154 | ˆ<br>170             | <br>186  | Ł<br>202 | ı<br>218 | Û<br>234 | ˆ<br>250             |
| B   | 1011 | ï<br>139 | ø<br>155 | $\frac{1}{2}$<br>171 | ¶<br>187 | Ṭ<br>203 | ■<br>219 | Û<br>235 | <sup>1</sup><br>251  |
| C   | 1100 | î<br>140 | £<br>156 | $\frac{1}{4}$<br>172 | ¶<br>188 | †<br>204 | ■<br>220 | ý<br>236 | <sup>3</sup><br>252  |
| D   | 1101 | ì<br>141 | Ø<br>157 | ı<br>173             | Φ<br>189 | =<br>205 | ı<br>221 | Ÿ<br>237 | <sup>2</sup><br>253  |
| E   | 1110 | Ä<br>142 | ×<br>158 | «<br>174             | ¥<br>190 | †<br>206 | î<br>222 | ■<br>238 | 254                  |
| F   | 1111 | Å<br>143 | f<br>159 | »<br>175             | ˆ<br>191 | Ǿ<br>207 | ■<br>223 | ˆ<br>239 | SP<br>255            |

|     | HEX  | 8        | 9        | A        | B        | C        | D        | E        | F         |
|-----|------|----------|----------|----------|----------|----------|----------|----------|-----------|
| HEX | BIN  | 1000     | 1001     | 1010     | 1011     | 1100     | 1101     | 1110     | 1111      |
| 0   | 0000 | Ç<br>128 | É<br>144 | á<br>160 | ☐<br>176 | ┘<br>192 | ┘<br>208 | α<br>224 | ≡<br>240  |
| 1   | 0001 | ü<br>129 | Ä<br>145 | í<br>161 | ☐<br>177 | ┘<br>193 | τ<br>209 | β<br>225 | ±<br>241  |
| 2   | 0010 | é<br>130 | È<br>146 | ó<br>162 | ☐<br>178 | ┘<br>194 | τ<br>210 | γ<br>226 | ≥<br>242  |
| 3   | 0011 | â<br>131 | ô<br>147 | ú<br>163 | <br>179  | ┘<br>195 | ┘<br>211 | π<br>227 | ≤<br>243  |
| 4   | 0100 | ã<br>132 | õ<br>148 | ñ<br>164 | ┘<br>180 | —<br>196 | ┘<br>212 | Σ<br>228 | ƒ<br>244  |
| 5   | 0101 | à<br>133 | ò<br>149 | Ñ<br>165 | ┘<br>181 | +        | ┘<br>213 | σ<br>229 | ∫<br>245  |
| 6   | 0110 | Á<br>134 | Ú<br>150 | ä<br>166 | ┘<br>182 | ┘<br>198 | ┘<br>214 | μ<br>230 | ÷<br>246  |
| 7   | 0111 | ç<br>135 | ù<br>151 | ó<br>167 | ┘<br>183 | ┘<br>199 | ┘<br>215 | τ<br>231 | ≈<br>247  |
| 8   | 1000 | ê<br>136 | î<br>152 | ç<br>168 | ┘<br>184 | ┘<br>200 | ┘<br>216 | Φ<br>232 | °<br>248  |
| 9   | 1001 | Ê<br>137 | Ï<br>153 | ö<br>169 | ┘<br>185 | ┘<br>201 | ┘<br>217 | θ<br>233 | •<br>249  |
| A   | 1010 | è<br>138 | Û<br>154 | ˘<br>170 | <br>186  | ┘<br>202 | ┘<br>218 | Ω<br>234 | ·<br>250  |
| B   | 1011 | í<br>139 | ϕ<br>155 | ½<br>171 | ┘<br>187 | ┘<br>203 | ■<br>219 | δ<br>235 | √<br>251  |
| C   | 1100 | ô<br>140 | £<br>156 | ¼<br>172 | ┘<br>188 | ┘<br>204 | ■<br>220 | ∞<br>236 | n<br>252  |
| D   | 1101 | ì<br>141 | Û<br>157 | ı<br>173 | ┘<br>189 | —<br>205 | ■<br>221 | ∅<br>237 | ²<br>253  |
| E   | 1110 | Ã<br>142 | Þ<br>158 | «<br>174 | ┘<br>190 | ┘<br>206 | ■<br>222 | ε<br>238 | ■<br>254  |
| F   | 1111 | Â<br>143 | Ó<br>159 | »<br>175 | ┘<br>191 | ┘<br>207 | ■<br>223 | ∩<br>239 | SP<br>255 |

|     | HEX  | 8        | 9        | A         | B        | C        | D        | E        | F         |
|-----|------|----------|----------|-----------|----------|----------|----------|----------|-----------|
| HEX | BIN  | 1000     | 1001     | 1010      | 1011     | 1100     | 1101     | 1110     | 1111      |
| 0   | 0000 | Ç<br>128 | É<br>144 | Ï<br>160  | Ï<br>176 | Ł<br>192 | Ł<br>208 | α<br>224 | ≡<br>240  |
| 1   | 0001 | Û<br>129 | È<br>145 | Ï<br>161  | Ï<br>177 | Ł<br>193 | Ŧ<br>209 | β<br>225 | ±<br>241  |
| 2   | 0010 | é<br>130 | È<br>146 | ó<br>162  | Ï<br>178 | Ŧ<br>194 | Ŧ<br>210 | Γ<br>226 | ≥<br>242  |
| 3   | 0011 | â<br>131 | ô<br>147 | ú<br>163  | Ï<br>179 | Ŧ<br>195 | Ł<br>211 | π<br>227 | ≤<br>243  |
| 4   | 0100 | Ā<br>132 | È<br>148 | Ï<br>164  | Ï<br>180 | —<br>196 | Ł<br>212 | Σ<br>228 | †<br>244  |
| 5   | 0101 | à<br>133 | Ï<br>149 | Δ<br>165  | †<br>181 | †<br>197 | Ŧ<br>213 | σ<br>229 | ‡<br>245  |
| 6   | 0110 | ¶<br>134 | û<br>150 | ³<br>166  | ¶<br>182 | ¶<br>198 | Ŧ<br>214 | μ<br>230 | ÷<br>246  |
| 7   | 0111 | ç<br>135 | ù<br>151 | —<br>167  | ¶<br>183 | †<br>199 | †<br>215 | τ<br>231 | ≈<br>247  |
| 8   | 1000 | ê<br>136 | œ<br>152 | î<br>168  | ¶<br>184 | Ł<br>200 | †<br>216 | φ<br>232 | °<br>248  |
| 9   | 1001 | ë<br>137 | ô<br>153 | Ŧ<br>169  | ¶<br>185 | Ŧ<br>201 | Ŧ<br>217 | θ<br>233 | •<br>249  |
| A   | 1010 | è<br>138 | Û<br>154 | Ŧ<br>170  | ¶<br>186 | Ł<br>202 | Ŧ<br>218 | Ω<br>234 | ·<br>250  |
| B   | 1011 | ï<br>139 | φ<br>155 | ½<br>171  | ¶<br>187 | Ŧ<br>203 | ■<br>219 | δ<br>235 | √<br>251  |
| C   | 1100 | î<br>140 | £<br>156 | ¼<br>172  | ¶<br>188 | Ŧ<br>204 | ■<br>220 | ∞<br>236 | n<br>252  |
| D   | 1101 | —<br>141 | Û<br>157 | ¾<br>173  | ¶<br>189 | —<br>205 | ■<br>221 | ∅<br>237 | ²<br>253  |
| E   | 1110 | Ā<br>142 | Ŧ<br>158 | <<<br>174 | ¶<br>190 | †<br>206 | ■<br>222 | ε<br>238 | ■<br>254  |
| F   | 1111 | §<br>143 | f<br>159 | >><br>175 | ¶<br>191 | Ł<br>207 | ■<br>223 | ∩<br>239 | SP<br>255 |



|     | HEX  | 8        | 9        | A        | B        | C        | D        | E        | F         |
|-----|------|----------|----------|----------|----------|----------|----------|----------|-----------|
| HEX | BIN  | 1000     | 1001     | 1010     | 1011     | 1100     | 1101     | 1110     | 1111      |
| 0   | 0000 | Ç<br>128 | Ě<br>144 | ǎ<br>160 | ⌘<br>176 | ⌚<br>192 | ⌛<br>208 | α<br>224 | ≡<br>240  |
| 1   | 0001 | ü<br>129 | æ<br>145 | í<br>161 | ⌘<br>177 | ⌚<br>193 | ⌛<br>209 | β<br>225 | ±<br>241  |
| 2   | 0010 | é<br>130 | Æ<br>146 | ó<br>162 | ⌘<br>178 | ⌚<br>194 | ⌛<br>210 | Γ<br>226 | ≥<br>242  |
| 3   | 0011 | â<br>131 | ô<br>147 | ú<br>163 | <br>179  | ⌚<br>195 | ⌛<br>211 | π<br>227 | ≤<br>243  |
| 4   | 0100 | ä<br>132 | ö<br>148 | ñ<br>164 | ⌚<br>180 | —<br>196 | ⌛<br>212 | Σ<br>228 | ↑<br>244  |
| 5   | 0101 | à<br>133 | ò<br>149 | Ñ<br>165 | ⌚<br>181 | ⌚<br>197 | ⌛<br>213 | σ<br>229 | ↓<br>245  |
| 6   | 0110 | å<br>134 | û<br>150 | ä<br>166 | ⌚<br>182 | ⌚<br>198 | ⌛<br>214 | μ<br>230 | ÷<br>246  |
| 7   | 0111 | ç<br>135 | ù<br>151 | ó<br>167 | ⌚<br>183 | ⌚<br>199 | ⌛<br>215 | τ<br>231 | ≈<br>247  |
| 8   | 1000 | ê<br>136 | ÿ<br>152 | č<br>168 | ⌚<br>184 | ⌚<br>200 | ⌛<br>216 | φ<br>232 | °<br>248  |
| 9   | 1001 | ë<br>137 | Ö<br>153 | ř<br>169 | ⌚<br>185 | ⌚<br>201 | ⌛<br>217 | θ<br>233 | •<br>249  |
| A   | 1010 | è<br>138 | Û<br>154 | ⌚<br>170 | ⌚<br>186 | ⌚<br>202 | ⌛<br>218 | Ω<br>234 | ·<br>250  |
| B   | 1011 | ï<br>139 | ø<br>155 | ½<br>171 | ⌚<br>187 | ⌚<br>203 | ■<br>219 | δ<br>235 | √<br>251  |
| C   | 1100 | î<br>140 | £<br>156 | ¼<br>172 | ⌚<br>188 | ⌚<br>204 | ■<br>220 | ∞<br>236 | n<br>252  |
| D   | 1101 | ï<br>141 | Ø<br>157 | ı<br>173 | ⌚<br>189 | ⌚<br>205 | ■<br>221 | ∅<br>237 | ²<br>253  |
| E   | 1110 | Ä<br>142 | Þ<br>158 | «<br>174 | ⌚<br>190 | ⌚<br>206 | ■<br>222 | €<br>238 | ■<br>254  |
| F   | 1111 | Å<br>143 | f<br>159 | ⌚<br>175 | ⌚<br>191 | ⌚<br>207 | ■<br>223 | ∩<br>239 | SP<br>255 |

|     | HEX  | 8         | 9         | A         | B         | C         | D         | E         | F         |
|-----|------|-----------|-----------|-----------|-----------|-----------|-----------|-----------|-----------|
| HEX | BIN  | 1000      | 1001      | 1010      | 1011      | 1100      | 1101      | 1110      | 1111      |
| 0   | 0000 | SP<br>128 | SP<br>144 | SP<br>160 | SP<br>176 | SP<br>192 | SP<br>208 | SP<br>224 | SP<br>240 |
| 1   | 0001 | SP<br>129 | SP<br>145 | SP<br>161 | SP<br>177 | SP<br>193 | SP<br>209 | SP<br>225 | SP<br>241 |
| 2   | 0010 | SP<br>130 | SP<br>146 | SP<br>162 | SP<br>178 | SP<br>194 | SP<br>210 | SP<br>226 | SP<br>242 |
| 3   | 0011 | SP<br>131 | SP<br>147 | SP<br>163 | SP<br>179 | SP<br>195 | SP<br>211 | SP<br>227 | SP<br>243 |
| 4   | 0100 | SP<br>132 | ö<br>148  | SP<br>164 | SP<br>180 | SP<br>196 | SP<br>212 | SP<br>228 | SP<br>244 |
| 5   | 0101 | SP<br>133 | SP<br>149 | SP<br>165 | SP<br>181 | SP<br>197 | SP<br>213 | SP<br>229 | SP<br>245 |
| 6   | 0110 | SP<br>134 | SP<br>150 | SP<br>166 | SP<br>182 | SP<br>198 | SP<br>214 | SP<br>230 | SP<br>246 |
| 7   | 0111 | SP<br>135 | SP<br>151 | SP<br>167 | SP<br>183 | SP<br>199 | SP<br>215 | SP<br>231 | SP<br>247 |
| 8   | 1000 | SP<br>136 | SP<br>152 | SP<br>168 | SP<br>184 | SP<br>200 | SP<br>216 | SP<br>232 | SP<br>248 |
| 9   | 1001 | SP<br>137 | SP<br>153 | SP<br>169 | SP<br>185 | SP<br>201 | SP<br>217 | SP<br>233 | SP<br>249 |
| A   | 1010 | SP<br>138 | SP<br>154 | SP<br>170 | SP<br>186 | SP<br>202 | SP<br>218 | SP<br>234 | SP<br>250 |
| B   | 1011 | SP<br>139 | SP<br>155 | SP<br>171 | SP<br>187 | SP<br>203 | SP<br>219 | SP<br>235 | SP<br>251 |
| C   | 1100 | SP<br>140 | SP<br>156 | SP<br>172 | SP<br>188 | SP<br>204 | SP<br>220 | SP<br>236 | SP<br>252 |
| D   | 1101 | SP<br>141 | SP<br>157 | SP<br>173 | SP<br>189 | SP<br>205 | SP<br>221 | SP<br>237 | SP<br>253 |
| E   | 1110 | SP<br>142 | SP<br>158 | SP<br>174 | SP<br>190 | SP<br>206 | SP<br>222 | SP<br>238 | SP<br>254 |
| F   | 1111 | SP<br>143 | SP<br>159 | SP<br>175 | SP<br>191 | SP<br>207 | SP<br>223 | SP<br>239 | SP<br>255 |

|     | HEX  | 8         | 9         | A         | B         | C         | D         | E         | F         |
|-----|------|-----------|-----------|-----------|-----------|-----------|-----------|-----------|-----------|
| HEX | BIN  | 1000      | 1001      | 1010      | 1011      | 1100      | 1101      | 1110      | 1111      |
| 0   | 0000 | SP<br>128 | SP<br>144 | SP<br>160 | SP<br>176 | SP<br>192 | SP<br>208 | SP<br>224 | SP<br>240 |
| 1   | 0001 | SP<br>129 | SP<br>145 | SP<br>161 | SP<br>177 | SP<br>193 | SP<br>209 | SP<br>225 | SP<br>241 |
| 2   | 0010 | SP<br>130 | SP<br>146 | SP<br>162 | SP<br>178 | SP<br>194 | SP<br>210 | SP<br>226 | SP<br>242 |
| 3   | 0011 | SP<br>131 | SP<br>147 | SP<br>163 | SP<br>179 | SP<br>195 | SP<br>211 | SP<br>227 | SP<br>243 |
| 4   | 0100 | SP<br>132 | ö<br>148  | SP<br>164 | SP<br>180 | SP<br>196 | SP<br>212 | SP<br>228 | SP<br>244 |
| 5   | 0101 | SP<br>133 | SP<br>149 | SP<br>165 | SP<br>181 | SP<br>197 | SP<br>213 | SP<br>229 | SP<br>245 |
| 6   | 0110 | SP<br>134 | SP<br>150 | SP<br>166 | SP<br>182 | SP<br>198 | SP<br>214 | SP<br>230 | SP<br>246 |
| 7   | 0111 | SP<br>135 | SP<br>151 | SP<br>167 | SP<br>183 | SP<br>199 | SP<br>215 | SP<br>231 | SP<br>247 |
| 8   | 1000 | SP<br>136 | SP<br>152 | SP<br>168 | SP<br>184 | SP<br>200 | SP<br>216 | SP<br>232 | SP<br>248 |
| 9   | 1001 | SP<br>137 | SP<br>153 | SP<br>169 | SP<br>185 | SP<br>201 | SP<br>217 | SP<br>233 | SP<br>249 |
| A   | 1010 | SP<br>138 | SP<br>154 | SP<br>170 | SP<br>186 | SP<br>202 | SP<br>218 | SP<br>234 | SP<br>250 |
| B   | 1011 | SP<br>139 | SP<br>155 | SP<br>171 | SP<br>187 | SP<br>203 | SP<br>219 | SP<br>235 | SP<br>251 |
| C   | 1100 | SP<br>140 | SP<br>156 | SP<br>172 | SP<br>188 | SP<br>204 | SP<br>220 | SP<br>236 | SP<br>252 |
| D   | 1101 | SP<br>141 | SP<br>157 | SP<br>173 | SP<br>189 | SP<br>205 | SP<br>221 | SP<br>237 | SP<br>253 |
| E   | 1110 | SP<br>142 | SP<br>158 | SP<br>174 | SP<br>190 | SP<br>206 | SP<br>222 | SP<br>238 | SP<br>254 |
| F   | 1111 | SP<br>143 | SP<br>159 | SP<br>175 | SP<br>191 | SP<br>207 | SP<br>223 | SP<br>239 | SP<br>255 |

## International character set

| Country    | ASCII code (hexadecimal) |    |    |    |    |    |    |    |    |     |     |     |     |
|------------|--------------------------|----|----|----|----|----|----|----|----|-----|-----|-----|-----|
|            | Hex                      | 23 | 24 | 40 | 5B | 5C | 5D | 5E | 60 | 7B  | 7C  | 7D  | 7E  |
|            | Dec                      | 35 | 36 | 64 | 91 | 92 | 93 | 94 | 96 | 123 | 124 | 125 | 126 |
| U.S.A.     | #                        | \$ | @  | [  | \  | ]  | ^  | `  | {  |     | }   | ~   |     |
| France     | #                        | \$ | à  | °  | ç  | §  | ^  | `  | é  | ù   | è   | ''  |     |
| Germany    | #                        | \$ | §  | Ä  | Ö  | Ü  | ^  | `  | ä  | ö   | ü   | ß   |     |
| U.K.       | £                        | \$ | @  | [  | \  | ]  | ^  | `  | {  |     | }   | ~   |     |
| Denmark I  | #                        | \$ | @  | Æ  | Ø  | Å  | ^  | `  | œ  | ø   | å   | ~   |     |
| Sweden     | #                        | α  | É  | Ä  | Ö  | Å  | Ü  | é  | ä  | ö   | å   | ü   |     |
| Italy      | #                        | \$ | @  | °  | \  | é  | ^  | ù  | à  | ò   | è   | ì   |     |
| Spain      | Pt                       | \$ | @  | ı  | Ñ  | ı  | ^  | `  | '' | ñ   | }   | ~   |     |
| Japan      | #                        | \$ | @  | [  | ¥  | ]  | ^  | `  | {  |     | }   | ~   |     |
| Norway     | #                        | α  | É  | Æ  | Ø  | Å  | Ü  | é  | œ  | ø   | å   | ü   |     |
| Denmark II | #                        | \$ | É  | Æ  | Ø  | Å  | Ü  | é  | œ  | ø   | å   | ü   |     |



# WEEE (Waste Electrical and Electronic Equipment) Directive

This information only applies to customers in the European Union, according to Directive 2002/96/EC OF THE EUROPEAN PARLIAMENT AND OF THE COUNCIL OF 27 January 2003 on waste electrical and electronic equipment (WEEE) and legislation transposing and implementing it into the various national legal systems.

For other countries, please contact your local government to investigate the possibility of recycling your product.



## English

The crossed out wheeled bin label that can be found on your product indicates that this product should not be disposed of via the normal household waste stream. To prevent possible harm to the environment or human health please separate this product from other waste streams to ensure that it can be recycled in an environmentally sound manner. For more details on available collection facilities please contact your local government office or the retailer where you purchased this product.

## Deutsch

Der Aufkleber mit durchgekreuzter Mülltonne an diesem Produkt weist darauf hin, dass dieses Produkt nicht im normalen Hausmüll entsorgt werden darf. Zur Vermeidung einer möglichen Beeinträchtigung der Umwelt oder der menschlichen Gesundheit und um zu gewährleisten, dass es in einer umweltverträglichen Weise recycelt wird, darf dieses Produkt nicht in den Hausmüll gegeben werden. Informationen zu Entsorgungseinrichtungen erhalten Sie bei der zuständigen Behörde oder dem Geschäft, in dem Sie dieses Produkt erworben haben.

## Français

L'étiquette apposée sur ce produit et représentant une poubelle barrée indique que le produit ne peut être mis au rebut avec les déchets domestiques normaux. Afin d'éviter d'éventuels dommages au niveau de l'environnement ou sur la santé, veuillez séparer ce produit des autres déchets de manière à garantir qu'il soit recyclé de manière sûre au niveau environnemental. Pour plus de détails sur les sites de collecte existants, veuillez contacter l'administration locale ou le détaillant auprès duquel vous avez acheté ce produit.

## Italiano

L'etichetta con il contenitore barrato applicata sull'imballo indica che il prodotto non deve essere smaltito tramite la procedura normale di smaltimento dei rifiuti domestici. Per evitare eventuali danni all'ambiente e alla salute umana, separare questo prodotto da altri rifiuti domestici in modo che possa essere riciclato in base alle procedure di rispetto dell'ambiente. Per maggiori dettagli sulle strutture di raccolta disponibili, contattare l'ufficio competente del proprio comune o il rivenditore del prodotto.

## Español

La etiqueta de un contenedor tachado que hallará en su producto indica que este producto no se puede tirar con la basura doméstica normal. Para impedir posibles daños medioambientales o para la salud, separe este producto de otros canales de desecho para garantizar que se recicle de una forma segura para el medio ambiente. Para más información sobre las instalaciones de recolección disponibles, diríjase a las autoridades locales o al punto de venta donde adquirió este producto.

## Português

A etiqueta com o símbolo de um contentor de lixo traçado com uma cruz que aparece no produto indica que este produto não deve ser deixado fora juntamente com o lixo doméstico. Para evitar possíveis danos ao ambiente ou na saúde pública, por favor separe este produto de outros lixos; desta forma, terá a certeza de que pode ser reciclado através de métodos não prejudiciais ao ambiente. Para obter mais informações sobre os locais de recolha de lixo disponíveis, contacte a sua junta de freguesia, câmara municipal ou local onde comprou este produto.

## Nederlands

Op uw product is een label van een rolcontainer met een kruis erdoor aangebracht. Dit label wil zeggen dat dit product niet bij het normale huishoudelijk afval mag worden ingezameld. Om eventuele schade aan het milieu of de gezondheid van de mens te voorkomen moet dit product gescheiden van al het ander afval worden ingezameld, zodat het op een verantwoorde wijze kan worden verwerkt. Voor meer informatie over uw lokale afvalinzameling wendt u zich tot uw gemeente of de leverancier bij wie u dit product hebt gekocht.

## Dansk

Etiketten med et kryds over skraldespanden på hjul, der sidder på produktet, angiver, at dette produkt ikke må bortskaffes sammen med almindeligt husholdningsaffald. For at beskytte miljø og helbred skal dette produkt bortskaffes separat, så det kan genbruges på en måde, der er god for miljøet. Kontakt de lokale myndigheder eller den forhandler, hos hvem du har købt produktet, vedrørende steder, hvor du kan aflevere produktet.

## Suomi

Laitte on merkitty jäteastia-symbolilla, jonka yli on vedetty rasti. Tämä tarkoittaa, ettei laitetta saa hävittää normaalin talousjätteen mukana. Älä hävittä laitetta normaalin jätteen seassa vaan varmista, että laite kierrätetään ympäristöystävällisellä tavalla, jottei ympäristölle tai ihmisille aiheudu vahinkoa. Lisätietoja kierrätyksestä ja keräyspisteistä saa ottamalla yhteyttä paikallisiin viranomaisiin tai jälleenmyyjään, jolta laite ostettiin.

## Svenska

Symbolen med en överkorsad soptunna innebär att denna produkt inte får kastas i vanligt hushållsavfall. För att skydda miljön ska denna produkt inte kastas tillsammans med vanligt hushållsavfall utan lämnas för återvinning på tillbörligt sätt. För mer information om uppsamlingsplatser kontakta din lokala myndighet eller den återförsäljare där du har köpt produkten.

## Norsk

Det er krysset over merket av beholderen på hjul som vises på produktet, som angir at dette produktet ikke skal kastes sammen med vanlig husholdningsavfall. Hold dette produktet atskilt fra annet avfall slik at det kan resirkuleres på en miljømessig forsvarlig måte og dermed forhindre eventuell skade på miljø eller helse. Hvis du vil ha mer informasjon om hvor produktet kan leveres inn, kontakter du kommunale myndigheter eller forhandleren der du kjøpte dette produktet.

---

## Česky

Štítek s přeškrtnutým odpadkovým košem na kolečkách, který lze nalézt na výrobku, označuje, že tento produkt se nemá likvidovat s běžným domovním odpadem. V zájmu ochrany životního prostředí a lidského zdraví zlikvidujte tento výrobek jako tříděný odpad, který se recykluje způsobem šetrným k životnímu prostředí. Podrobnější informace o sběrných dvorech pro tříděný odpad získáte na obecním úřadě nebo u prodejce, u kterého jste příslušný výrobek zakoupili.

---

## Magyar

A terméken található, áthúzott szemetest ábrázoló címke azt jelzi, hogy ezt a terméket nem szabad a rendszer háztartási szeméttel együtt kidobni. Az esetleges környezeti- vagy egészségkárosodást megelőzendő, kérjük, hogy ezt a terméket a többi szeméttől elkülönítve helyezze el, és biztosítsa, hogy azt környezetbarát módon újrahasznosítsák. A rendelkezésére álló begyűjtő létesítményekről kérjük tájékozódjon a megfelelő helyi állami szerveknél vagy a viszonteladónál, ahol a terméket vásárolta.

---

## Polski

Symbol przekreślonego kosza znajdujący się na produkcie oznacza, że nie może on być utylizowany razem z normalnymi odpadami z gospodarstwa domowego. Aby zapobiec potencjalnemu zagrożeniu dla środowiska lub zdrowia ludzkiego, produkt ten należy odseparować od reszty odpadów z gospodarstwa domowego i utylizować w ekologicznie właściwy sposób. Szczegółowe informacje na temat punktów zbiórki odpadów można uzyskać w lokalnych urzędach lub u sprzedawcy danego produktu.

---

## Slovensky

Štítko s přeškrtnutým odpadkovým košom na kolieskach, ktorý je možné nájsť na výrobku, označuje, že tento produkt sa nemá likvidovať s bežným komunálnym odpadom. V záujme ochrany životného prostredia a ľudského zdravia zlikvidujte tento výrobok ako triedený odpad, ktorý sa recykluje spôsobom šetrným k životnému prostrediu. Podrobnejšie informácie o zberných dvoroch pre triedený odpad získate na obecnom úrade alebo u predajcu, u ktorého ste príslušný výrobok zakúpili.

---

## Slovenski

Přečrtná koš za smeti na etiketi, katero lahko najdete na vašem izdelku, pomeni, da tega izdelka ne smete odvreči podobno kot vse ostale smeti. Da bi preprečili morebitne škodljive vplive na okolje ali zdravje, ločite izdelek od vseh ostalih in poskrbite, da bo recikliran na okolju prijazen način. Natančne informacije o tem, kje se nahajajo primerna odlagališča, pridobite v vašem krajevnem uradu ali pri prodajalcu.

---

## Eesti

Teie tootele kleebitud tähis, mis kujutab ratastega prügikonteinerit, millele on rist peale tõmmatud, keelab teote toote kõrvaldamise majapidamisjäätmetega sarnasel viisil. Keskkonnale või inimeste tervisele tekitatava võimaliku kahju vältimiseks eraldage toode teistest jäätmetest, et tagada selle korduvkasutamine keskkonnasäästlikul viisil. Kui soovite saada rohkem teavet võimalike kogumispunktide kohta, võtke ühendust kohaliku omavalitsuse ametnikuga või teile toote müünud jaemüüjaga.

---

## Lietuviški

Užbraukta ratuota šiukšliadėžės etiketė, kurią rasite ant jūsų produkto, reiškia, kad šis produktas neturėtų būti išmestas kartu su įprastinėmis buitinėmis šiukšlėmis. Siekiant išvengti galimos žalos aplinkai bei žmonių sveikatai, prašome atskirti šį produktą nuo kitų atliekų, ir įsitikinti, kad jis būtų perdirbtas aplinkai nepavojingu būdu. Jei reikia išsamesnės informacijos apie atliekų surinkimo ypatumus, prašome kreiptis į savo vietos valdžios įstaigas arba į mažmeninį pardavėją, iš kurio jūs įsigijote šį produktą.

---

## Latviski

Marķējums ar pārsvīrotu atkritumu tvertni uz rītenīšiem, kas redzams uz izstrādājuma, norāda, ka šo izstrādājumu nedrīkst likvidēt kopā ar parastajiem sadzīves atkritumiem. Lai novērstu iespējamo kaitējumu videi vai cilvēku veselībai, lūdzam, atdaliet šo izstrādājumu no citiem atkritumiem, tādējādi nodrošinot tā otrreizējo pārstrādi videi drošā veidā. Papildinformācijai par pieejamajām atkritumu savākšanas iespējām, lūdzam, sazinieties ar vietējo pašvaldību vai mazumtirgotāju, no kura jūs iegādājāties šo izstrādājumu.

---

## Ελληνικά

Η διαγραμμένη ετικέτα του τροχοφόρου κάδου απορριμμάτων που θα βρείτε πάνω στο προϊόν σας υποδεικνύει ότι αυτό το προϊόν δεν πρέπει να απορριπτείται μέσω του κανονικού δικτύου αποκομιδής οικιακών απορριμμάτων. Για να αποτρέψετε πιθανές επιπτώσεις στο περιβάλλον ή την ατομική υγεία, παρακαλούμε να διαχωρίσετε αυτό το προϊόν από άλλα δίκτυα αποκομιδής ώστε να διασφαλίσετε ότι είναι δυνατή η ανακύκλωσή του με έναν περιβαλλοντικά θεμιτό τρόπο. Για περισσότερες πληροφορίες σχετικά με τις διαθέσιμες δυνατότητες συλλογής απορριμμάτων, παρακαλούμε να επικοινωνήσετε με την τοπική κυβερνητική αρχή ή το κατάστημα λιανικής από όπου αγοράσατε αυτό το προϊόν.

---

## Türkçe

Ürününüzün üzerinde bulunan çarpi işaretli tekerlekli kutu etiketi, bu ürünün normal ev atık sistemi vasıtasıyla elden çıkarılmaması gerektiğini gösterir. Çevreye ve insan sağlığına zarar vermeyi önlemek için, lütfen bu ürünü çevreye zarar vermeyecek şekilde geri döndürme tabii tutulmak üzere diğer atıklardan ayırın. Mevcut toplama tesisleri ile ilgili ayrıntılı bilgi edinmek için, yerel devlet makamlarıyla veya bu ürünü satın aldığınız satıcıyla irtibata geçin.

---

## Română

Eticheta arătând un coș de gunoi tăiat cu două linii încrucișate, care poate fi găsită pe produs, indică faptul că acesta nu trebuie aruncat la gunoi laolaltă cu gunoiul menajer. Pentru a evita posibila degradare a mediului înconjurător sau a sănătății umane, colectați separat acest produs de gunoi menajer pentru a vă asigura că poate fi reciclat într-un mod ecologic. Pentru mai multe detalii privind punctele disponibile de colectare, contactați autoritățile locale sau comerciantul de la care ați achiziționat acest produs.

---

## Български

Етикетът, представляващ зачертано кошче за боклук в кръг, който можете да видите върху вашия продукт, означава, че този продукт не трябва да се изхвърля заедно с обикновените домакински отпадъци. За предпазване от евентуални щети върху околната среда или човешкото здраве, моля, отделете този продукт от останалите отпадъци, за да се гарантира, че той ще бъде рециклиран по екологично съобразен начин. За повече информация относно наличните места за събиране на отпадъци, моля, свържете се с местните власти или търговеца, от когото сте закупили този продукт.

Printed in China